

TECHNICAL DATA SHEET

S.4309 WIP APPLIQUE

SIMES
luce per l'architettura

-PRODUCT TYPE

Wall mounted luminaire .
IP rating IP 65

-MATERIAL CHARACTERISTICS

Aluminium die cast housing in EN AB-47100 with high resistance against corrosion.

Stone wash surface treatment prior to painting process.

A4 grade Stainless Steel screws with 2,5-3% molybdenum content which increases the resistance against corrosion.

Dutral gaskets.

Painting Process :

3 Step Process

1) Surface treatment with BONDERITE . A heavy metal free chemical surface treatment containing ceramic nano particles giving a cohesive, inorganic and highly dense protective coating .

2) PRE POLYMERIZATION a process of introducing an epoxy primer with excellent characteristics to the paint which also offers very high resistance to oxidation due to its Zinc content.

3) POLYMERIZATION a process with the application of polyester powder with high resistance against UV rays and harsh weather conditions. Improved protection for Marine applications.

Mechanical resistance of glass --

-LIGHTING PERFORMANCE

Reflector in 99.98% pure aluminium .

Pressed and sand blasted glass diffuser.

Lamp fixed position.

LOR 27%

-WIRING

Double cable entry .

Isolation: CLASS I .

Available colours: BLACK (cod.09), ALUMINIUM GREY (cod.14).

Weight: 2.24 Kg

Glow Wire test: 850°C

Lamp not included.

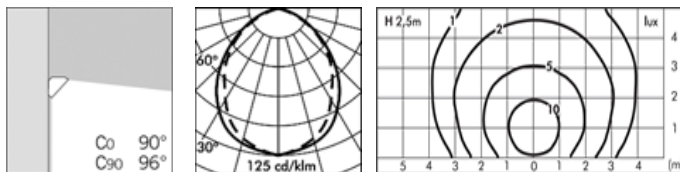

TC-D 18W G24d-2 1200 lm
Magnetic transformer 230÷240V 50Hz

IP 65

CE, RoHS, and other compliance symbols.

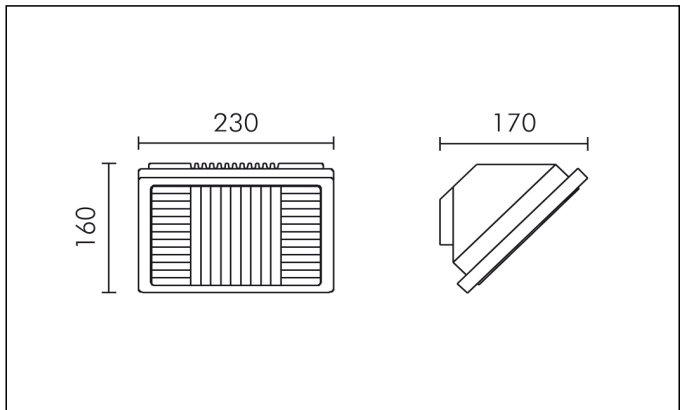

LAST UPDATE 14/09/2010

SIMES S.p.A.
Via G.Pastore 2/4
25040 - Corte Franca - BRESCIA (ITALY)
<http://www.simes.com> - e-mail: simes@simes.com

Tel: +39 0309860440
Export Sales: +39 0309860440
Technical Dep.: +39 0309860450
Lighting Design Dep.: +39 0309860425

Fax: +39 0309860449
Export Sales: +39 0309860459
Technical Dep.: +39 0309860459
Lighting Design Dep.: +39 0309860429



The present technical data sheet and all the information contained is property of SIMES S.p.A. All rights reserved.
We reserve the right to change specifications without prior written notice.

TECHNICAL DATA SHEET

S.4309

FURTHER INFORMATION

SIMES

luce per l'architettura

FIXING BASE

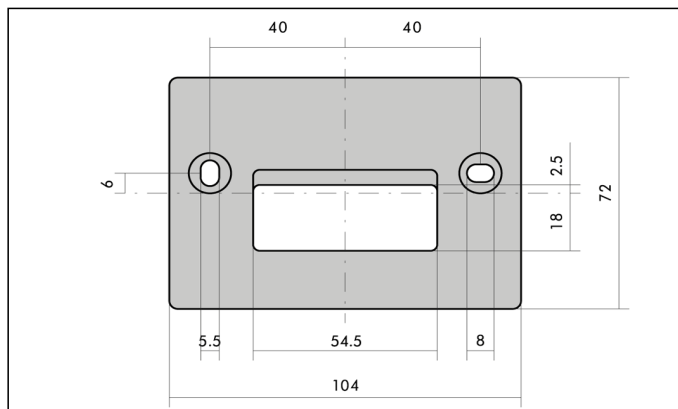

LAST UPDATE 14/09/2010

SIMES S.p.A.
Via G.Pastore 2/4
25040 - Corte Franca - BRESCIA (ITALY)
<http://www.simes.com> - e-mail: simes@simes.com

Tel:
Export Sales: +39 0309860440
Technical Dep. +39 0309860450
Lighting Design Dep.: +39 0309860425

Fax:
Export Sales: +39 0309860449
Technical Dep.: +39 0309860459
Lighting Design Dep.: +39 0309860429



The present technical data sheet and all the information contained is property of SIMES S.p.A. All rights reserved.
We reserve the right to change specifications without prior written notice.