

TECHNICAL DATA SHEET

S.4182 MINICOLUMN

SIMES
luce per l'architettura

-PRODUCT TYPE

Bollard fitting .
IP rating IP 65

-MATERIAL CHARACTERISTICS

Extruded EN AW-6060 aluminium profile, die-cast EN AB-44100 aluminium housing (copper free) with high corrosion resistance.

Stone wash surface treatment prior to painting process.

A4 grade Stainless Steel screws with 2,5-3% molybdenum content which increases the resistance against corrosion.

Pre treated Silicone Gaskets.

Painting Process :

3 Step Process

1) Surface treatment with BONDERITE . A heavy metal free chemical surface treatment containing ceramic nano particles giving a cohesive, inorganic and highly dense protective coating .

2) PRE POLYMERIZATION a process of introducing an epoxy primer with excellent characteristics to the paint which also offers very high resistance to oxidation due to its Zinc content.

3) POLYMERIZATION a process with the application of polyester powder with high resistance against UV rays and harsh weather conditions. Improved protection for Marine applications.

Mechanical resistance of glass IK 10

-LIGHTING PERFORMANCE

Clear polycarbonate lens with controlled downward light emission for avoiding any glare, UV-stabilised and vandalproof .

Lamp fixed position .

LOR 45%

-WIRING

Supplied with rubber cable H07RN-F and fast connector IP67. The connector must be connected at the supply line (\varnothing 12÷16 mm).

Isolation: CLASS II .

Available colours: BLACK (cod.09), ALUMINIUM GREY (cod.14).

Weight: 4.19 Kg

Glow Wire test: 750°C

Lamp not included.

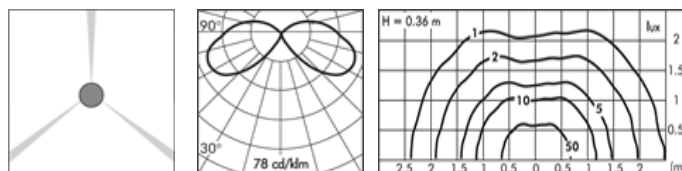
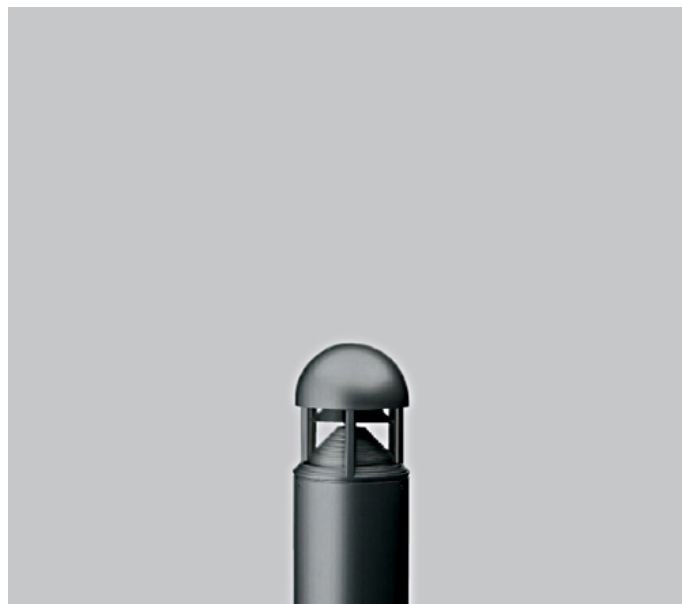

TC-T 18W Gx24d-2 1200 lm
Magnetic transformer 230÷240V 50Hz



IP 65

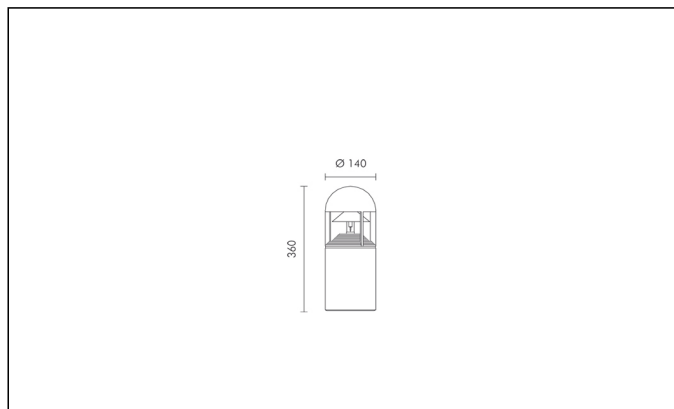

FAST CONNECTOR INCLUDED

LAST UPDATE 13/09/2010

SIMES S.p.A.
Via G.Pastore 2/4
25040 - Corte Franca - BRESCIA (ITALY)
<http://www.simes.com> - e-mail: simes@simes.com

Tel:
Export Sales: +39 0309860440
Technical Dep.: +39 0309860450
Lighting Design Dep.: +39 0309860425

Fax:
Export Sales: +39 0309860449
Technical Dep.: +39 0309860459
Lighting Design Dep.: +39 0309860429



The present technical data sheet and all the information contained is property of SIMES S.p.A. All rights reserved.
We reserve the right to change specifications without prior written notice.

S.4182

ACCESSORIES FOR MINICOLUMN



S.4172

FLANGE FOR MINICOLUMN

Flange \varnothing 140mm h 115mm to be fixed in concrete with stainless steel screws for fixing in the ground.

Footstall dimension can be calculated according to your country norms and ground properties.

Further information

FIXING BASE

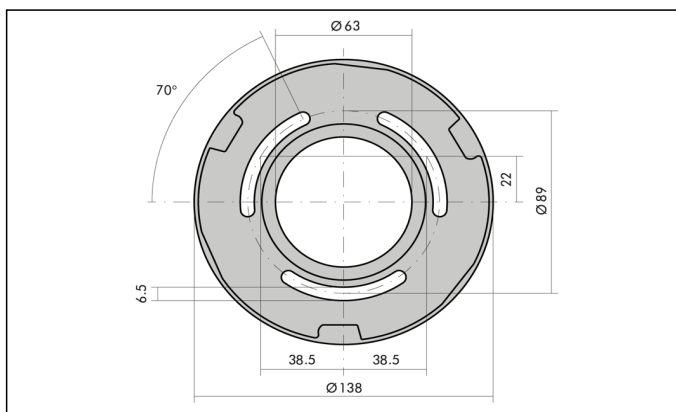

LAST UPDATE 13/09/2010

SIMES S.p.A.
Via G.Pastore 2/4
25040 - Corte Franca - BRESCIA (ITALY)
<http://www.simes.com> - e-mail: simes@simes.com

Tel:
Export Sales: +39 0309860440
Technical Dep. +39 0309860450
Lighting Design Dep.: +39 0309860425

Fax:
Export Sales: +39 0309860449
Technical Dep.: +39 0309860459
Lighting Design Dep.: +39 0309860429

